

Specification Check

◆ Before installation, please ensure that your bike frame and crankset meet the following specifications.

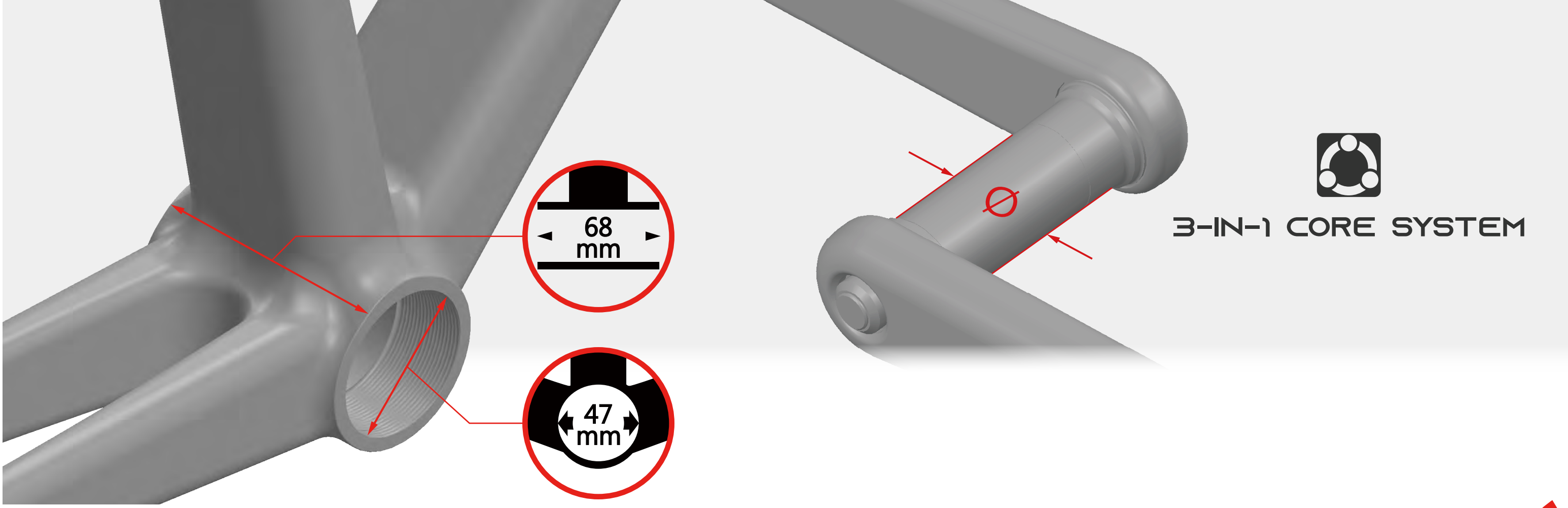

Bike Frame : T47-68
 Thread Type
 Inner Diameter : 47mm
 Width : 68mm

Crank Spec: **Shimano HT II : Ø24mm** ✓
SRAM DUB : Ø28.99mm ✓
ROTOR 3D+ : Ø30mm ✓

BB T47-68 Anatomy

◆ Before installation, please ensure that the purchased BB meets the following specifications and includes the following contents.



General Safety

- ◆ To install TRIPEAK Bottom Bracket, we strongly recommend that you have a trained bicycle mechanic at your local bike shop.
- ◆ Do not alter this product in any way as it can cause unseen damage. Any modifications to this product will void the warranty.
- ◆ Make sure the crankset is firmly attached to the bottom bracket, Improperly attached cranks can become detached from the BB set.
- ◆ When cleaning the bottom bracket set, only use mild soap and water. Never use high-pressure water jet, It will cause BB cup internal water ingress and influencing the bearing rolling lifetime.
- ◆ If you have any questions or concerns about this product, Please feel free to contact us. E-mail: info@tripeakbearing.com



Required Tools

TRIPEAK Tool Required : B015
 Tool compatible with torque wrench for installation use.

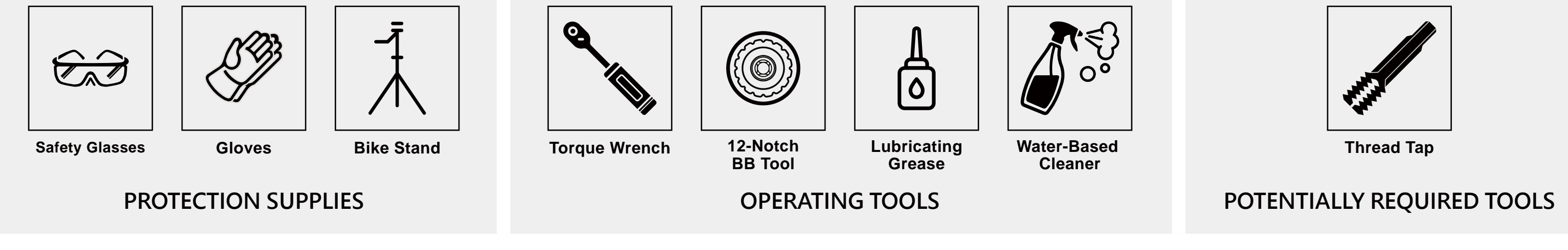

Bottom Bracket Installation

Use the included TRIPEAK ETERNA LV Fluid to Add a full lap of bearings. Rotate the bearings gently by hand to ensure the lubricant is evenly distributed.

Carefully press the seals back into place on the bearings, ensuring they are seated properly and securely.

Ensure the internal cable routing of the frame will not interfere with the BB installation. Clean the threads of the frame, and apply a thin layer of grease on the threads and the BB contact surface to prevent seizing with the BB shell.

Clean the threads on the BB shell, and apply a thin layer of grease. Remove the non-drive side BB shell and non-drive side tube, to be installed later.

Ensure the drive side BB shell and drive side tube are properly engaged. While inserting, ensure there is no interference between the BB tube and the internal cables of the frame.

Screw the drive side BB counterclockwise into the drive side of frame. After screwing in the drive side BB, use the BB cartridge wrench with the torque wrench to secure the BB shell to 30Nm.

⚠ If there is excessive resistance while screwing in, stop and check the thread alignment or for any thread damage. If there had damage, re-tap the threads before proceeding.

Ensure the non-drive side BB shell and non-drive tube are properly engaged. When inserting into the frame, ensure the tubes on both ends are aligned properly. Screw the non-drive side BB clockwise into the non-drive side of frame.

⚠ If there is excessive resistance while screwing in, stop and check the thread alignment or for any thread damage. If there had damage, re-tap the threads before proceeding.

After screwing in the BB of both side, use the BB cartridge wrench with the torque wrench to secure the BB shells to 30Nm Max.

Installation of Crank's Adapter

3-IN-1 CORE SYSTEM

SHIMANO HTII

1. Push tighten until click (Non-Drive Side Adapter)

2. Center Tube

3. Drive Side Adapter

4. Push tighten until click (Drive Side Adapter)

SRAM DUB

2. Non-Drive Side Adapter

3. Drive Side Adapter

4. Push tighten until click (Drive Side Adapter)

ROTOR 3D+

4. Non-Drive Side Adapter

4. Drive Side Adapter

Bottom Bracket Maintenance



- ◆ For maintaining and servicing TRIPEAK bottom brackets, we strongly recommend hiring a trained bicycle mechanic at your local bike shop.
- ◆ Regular maintenance is generally recommended after riding 5,000-10,000 km. If riding in harsh conditions (wet, dusty, extreme temperatures, etc.), it is advised to perform maintenance immediately after riding.
- ◆ Avoid repeated disassembly and reassembly of the BB Cup unless necessary, as maintenance should only focus on the BB bearings to prevent damage to the frame.
- ◆ Do not use high-pressure water jets to clean the BB to avoid water infiltration and bearing damage.
- ◆ Regularly check the torque value of the BB Cup, and do not ride with a loose BB Cup.
- ◆ Bearing specifications for T47-86 BB.
 | Drive Side : 42 x 30 x 7mm (6806-2RS) | Non-Drive : 42 x 30 x 7mm (6806-2RS)

Lubricant Recommendation



Reapply lubricant to Bottom Bracket

Carefully use a small tool to gently pry off the out outer seals from the bearings. Use a suitable solvent to clean the bearings thoroughly, removing old lubricant and any debris. Allow them to dry completely.

⚠ Be cautious not to damage the seals or the bearings.

Use TRIPEAK ETERNA LV Fluid or the appropriate lubricant to Add a full lap of bearings. Be sure to use the correct type of lubricant recommended for your specific bearings.

Rotate the bearings gently by hand to ensure the lubricant is evenly distributed.

Carefully press the seals back into place on the bearings, ensuring they are seated properly and securely.

After reassembly, check to ensure the bearings move smoothly and without resistance.